

Machine Screws

METRIC

Pan Head

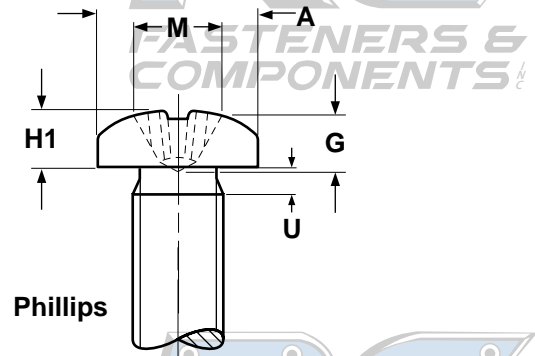
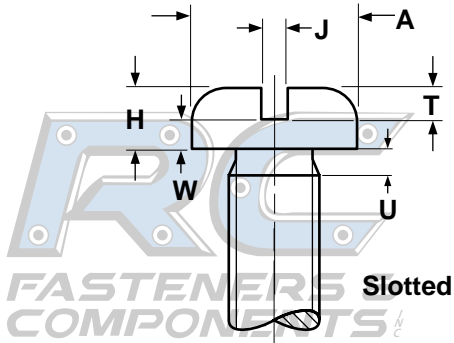

METRIC - PHILLIPS PAN HEADS FOR MACHINE SCREWS										ISO 7045
Nominal Size	Thread Pitch	A		H1		M	G		U	Phillips Driver Size
		Head Diameter		Height of Head		Recess Diameter	Recess Penetration		Thread Runout	
		Max	Min	Max	Min	Ref	Max	Min	Max	
M1.6	0.35	3.2	2.9	1.30	1.16	1.7	0.95	0.70	0.7	0
M2	0.4	4.0	3.7	1.60	1.46	1.9	1.2	0.9	0.8	0
M2.5	0.45	5.0	4.7	2.10	1.96	2.7	1.55	1.15	0.9	1
M3	0.5	5.6	5.3	2.40	2.26	3	1.8	1.4	1	1
M4	0.7	8.00	7.64	3.10	2.92	4.4	2.4	1.9	1.4	2
M5	0.8	9.50	9.14	3.70	3.52	4.9	2.9	2.4	1.6	2
M6	1	12.00	11.57	4.6	4.3	6.9	3.6	3.1	2	3
M8	1.25	16.00	15.57	6.0	5.7	9	4.6	4.0	2.5	4
M10	1.5	20.00	19.48	7.50	7.14	10.1	5.8	5.2	3	4

METRIC - SLOTTED PAN HEADS FOR MACHINE SCREWS										ISO 1580
Nominal Size	Thread Pitch	A		H		J		T	W	U
		Head Diameter		Head Height		Width of Slot		Depth of Slot	Wall Thickness	Thread Runout
		Max	Min	Max	Min	Max	Min	Min	Min	Max
M1.6	0.35	3.2	2.9	1.00	0.86	0.60	0.46	0.35	0.3	0.7
M2	0.4	4.0	3.7	1.30	1.16	0.70	0.56	0.5	0.4	0.8
M2.5	0.45	5.0	4.7	1.50	1.36	0.80	0.66	0.6	0.5	0.9
M3	0.5	5.6	5.3	1.80	1.66	1.00	0.86	0.7	0.7	1
M4	0.7	8.00	7.64	2.40	2.26	1.51	1.26	1	1	1.4
M5	0.8	9.50	9.14	3.00	2.86	1.51	1.26	1.2	1.2	1.6
M6	1	12.00	11.57	3.6	3.3	1.91	1.66	1.4	1.4	2
M8	1.25	16.00	15.57	4.8	4.5	2.31	2.06	1.9	1.9	2.5
M10	1.5	20.00	19.48	6.0	5.7	2.81	2.56	2.4	2.4	3