

**NUTS** DIN 6926 Nylon Insert Flange Style

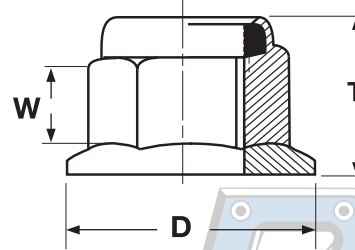
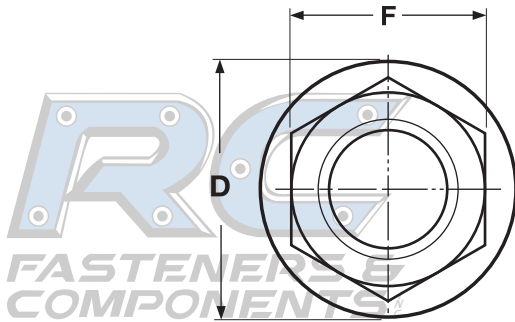

METRIC - DIN 6926 NYLON INSERT FLANGE STOP NUTS							DIN 6926
Nominal Size	Thread Pitch	F		D	T		W
		Width Across Flats		Flange Diameter	Total Thickness		Wrenching Height
		Max	Min	Min	Max	Min	Min
M5	0.8	8	7.78	11.8	7.1	6.74	2.2
M6	1	10	9.78	14.2	9.1	8.74	3.1
M8	1.25	13	12.73	17.9	11.1	10.67	4.5
M10	1.5	15	14.73	21.8	13.5	13.07	5.5
M12	1.75	18	17.73	26	16.1	15.67	6.7
M16	2	24	23.67	34.5	20.3	19.46	9
M20	2.5	30	29.16	42.8	24.8	23.96	11.1

<b>Description</b>	Hex nut with a nylon-filled collar at its back end and an enlarged circular base flaring out from the front end of the nut. When an externally threaded fastener reaches the collar, the threads and nylon form a tight, frictional fit as the nylon applies downward pressure that forces contact between the internal and external threads.
<b>Applications/ Advantages</b>	The nut may be reused up to 50 times, does not damage the threads of the fastener it is used with, withstands extreme vibrations without loosening. The flange design allows the nut to span larger holes than a standard nylon insert stop nut while providing a more uniform bearing-stress to clamp-force ratio.
<b>Material</b>	Class 8 metric nylon insert lock nuts shall be made of a steel which conforms to the following chemical composition-- <b>Carbon:</b> 0.58% maximum; <b>Manganese:</b> 0.25% minimum; <b>Phosphorus:</b> 0.060% maximum; <b>Sulfur:</b> 0.150% maximum. Insert is made of polyamid.
<b>Hardness</b>	HV 195 Minimum
<b>Plating</b>	See Appendix-A for plating information