

**RIVET NUTS (Blind Threaded Inserts)** **Thin Head Ribbed Body**

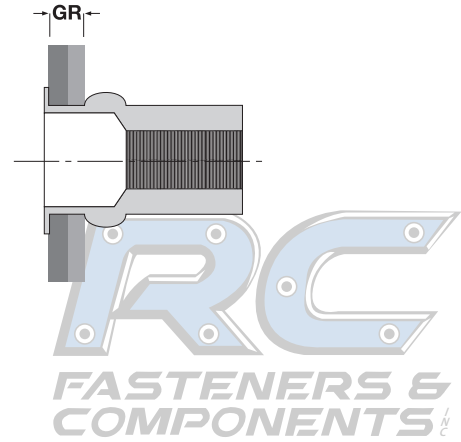

THIN HEAD, RIBBED BODY BLIND THREADED INSERT										
Thread Size	GR	L		A		B		C	Hole Size	
	Grip Range	Body Length		Body Diameter		Head Diameter		Head Height		
		Max	Min	Max	Min	Max	Min	Nom	Max	Min
M4 x 0.7 ISO	2.0 - 3.3	12.32	11.56	6.73	6.63	10.29	9.53	0.48	6.90	6.75
M6 x 1.0 ISO	0.7 - 4.2	15.11	14.35	9.91	9.81	11.94	11.18	0.55	10.15	10.00
M6 x 1.0 ISO	4.2 - 6.6	17.65	16.89	9.91	9.81	11.94	11.18	0.55	10.15	10.00
M10 x 1.50 ISO	0.7 - 3.8	17.91	17.15	13.46	13.36	15.49	14.73	0.55	13.65	13.50
M10 x 1.50 ISO	3.8 - 7.9	20.83	20.07	13.46	13.36	15.49	14.73	0.55	13.65	13.50

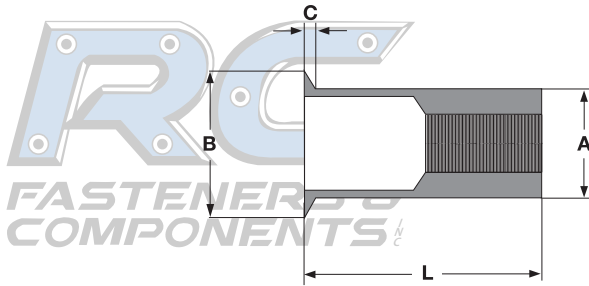

<b>Description</b>	A cylindrical internally threaded fastener with ribs that extend longitudinally from underneath the head down the outside of the insert. The head has a thinner profile and smaller diameter than the large flange variety. The fastener is open at both ends with a circular flange at one end that can be installed into a prepared hole from the blind side of the ultimate fastening. Insert is threaded onto mandrel of installation tool and positioned into hole. As mandrel is pulled back, the insert is expanded into the base material it is now gripping. Installation is complete when the mandrel of the tool is removed from the set insert.
<b>Applications / Advantages</b>	The thin head design enables the fastener to have a flush fit once seated in place. Used in electrical engineering, automotive, home appliances and other light-duty applications. Ribbed body offers greater torque-to-rotation resistance than non-ribbed bodies.
<b>Material</b>	Steel: 1108 or 1110 Steel

